

Stepless tool pressure control system

for VK Air Seal debarking rotor



Stepless tool pressure control system is available as a retro-fit product for all Valon Kone Air Seal debarking rotors, despite the manufacturing year of the VK debarker. The modification kit will be mounted on the customer's existing tool pressure cabinet.

Several satisfied VK customers in plywood factories and sawmills in different countries have already proven the benefits of this new more wood-saving system, compared to the previous 4-step system:

1. Stepless debarking pressure adjustment with 0,1 bar accuracy – adjustment from display panel
2. Quick and precise raise of pressure level from holding pressure to debarking pressure – debarking starts exactly at right time
3. Less log end damages
4. Less undebarbed log ends
5. Mechanically stronger construction, no compressed air leaks

Supply scope of modification kit for one debarking rotor:

- Proportional valve
- Directional valve
- Maintenance unit for compressed air
- Pressure transmitter
- Needed fittings and internal cables inside the debarker
- Mounting plate and needed fastening parts
- Updated sample programme for PLC (Siemens S7/TIA)
- Updated technical documentation

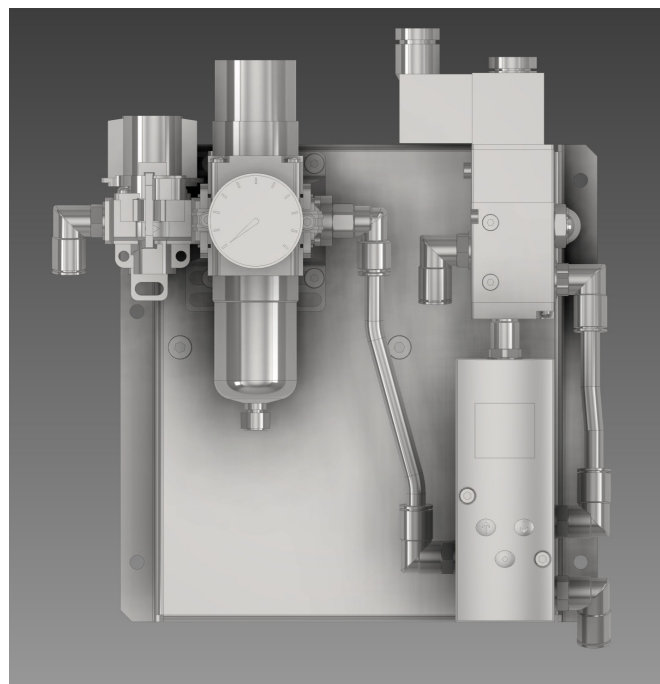

When inquiring about the new system, please inform us of the machine model/type, serial number, and manufacturing year. This will help us serve you better.

For example: Machine model VK5000HD-Combi-2R, machine number 123/2004

The machine's type number can also be in the format 5000HD-5056/5056-12-72-RHP